



50Ω TERMINATED 3GHz SMA LATCHING S.P.3 T. SWITCH

OPTIONS: /SELF CUT-OFF /AUTO RESET / TTL DRIVE /SUPP.DIODES

**R F CHARACTERISTICS**

NUMBER OF WAYS : 3  
 FREQUENCY RANGE : 0 - 3 GHz  
 IMPEDANCE : 50 Ohms

FREQUENCY (GHz)	0 - 3
V.S.W.R <=	1.20
INSERT. LOSS <=	0.20 dB
ISOLATION >=	80 dB
AVER. POWER (*)	240 W

TERMINATION IMPEDANCE : 50 Ohms  
 TERMINATION AVG. POWER AT 25° C : 1 W per termination  
 3 W total power

**ELECTRICAL CHARACTERISTICS**

ACTUATOR : LATCHING  
 NOMINAL CURRENT AT 25° C (±10%) : 640 mA  
 ACTUATOR VOLTAGE (Vcc) : 12V (10.2 to 13V) / NEGATIVE COMMON  
 TERMINALS : solder pins (250°C max./30 sec.)  
 SELF CUT-OFF TIME : 40 ms < CT < 120 ms  
 TTL INPUTS (E) - High level : 2.2 to 5.5V / 800µA at 5V  
 - Low level : 0 to 0.8V / 20µA at 0.8V

**MECHANICAL CHARACTERISTICS**

CONNECTORS : SMA female per MIL-C 39012  
 LIFE : 2.000.000 cycles per position  
 SWITCHING TIME (nominal voltage;25° C) : < 40 ms  
 CONSTRUCTION : splashproof  
 WEIGHT : < 250 g

**ENVIRONMENTAL CHARACTERISTICS**

OPERATING TEMPERATURE RANGE (°C) : -40 , +85  
 STORAGE TEMPERATURE RANGE (°C) : -55 , +85

(\* : average power at 25° C per RF path)

This information is given as an indication. In the continual goal to improve our products, we reserve the right to make any modifications judged necessary

4113-9212 This information is given as an indication. In the continual goal to improve our products, we reserve the right to make any modifications judged necessary

**DRAWING**

General tolerance: ± 0,5 mm

**R574 382 320**

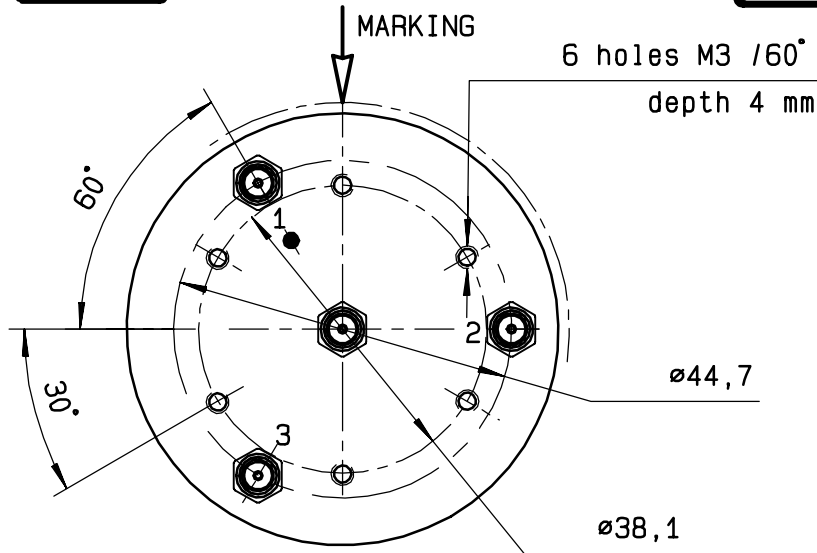

TTL input	RF continuity
E1 = 1	IN ↔ 1
E2 = 1	IN ↔ 2
E3 = 1	IN ↔ 3

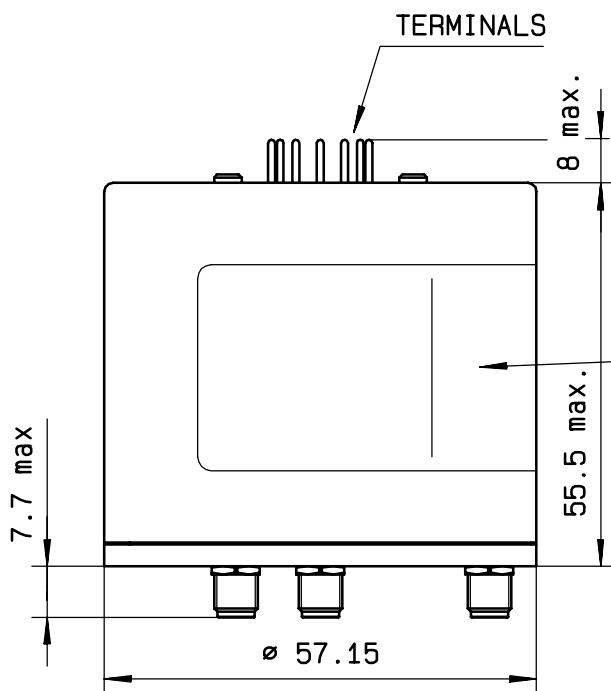

MARKING TOP VIEW (TERMINALS)

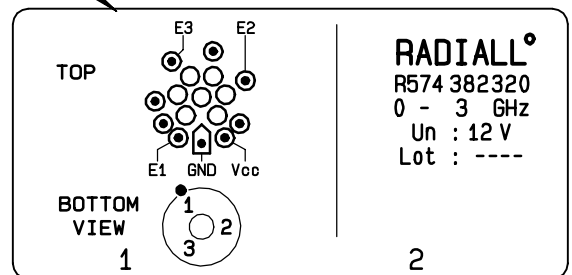

**SCHEMATIC DIAGRAM**

